

Fourier Transform

Nagarajan Murali

Rutgers, The State University of
New Jersey.

One Pulse Experiment

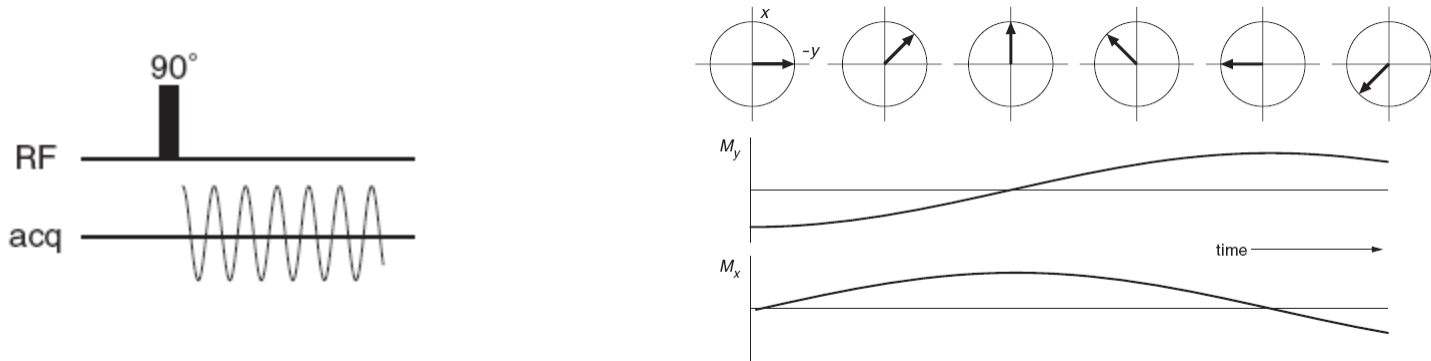

With a 90° pulse along x axis, the magnetization vector rotated from z to $-y$ and evolves with a precession frequency $\Omega = \omega_0 - \omega_{rot}$

$$M_y = -M_0 \cos(\Omega t)$$

$$M_x = M_0 \sin(\Omega t)$$

Through Fourier Transform one identifies the frequency and its sign (sense of rotation).

Free Induction Decay - FID

With a 90° pulse along x axis, the magnetization vector rotated from z to $-y$ then the observed FID is

$$S(t) = (M_y(t) - iM_x(t))e^{-t/T_2}$$

$$S(t) = -M_0(\cos(\Omega t) + i \sin(\Omega t))e^{-t/T_2}$$

$$S(t) = -M_0 e^{i\Omega t} e^{-t/T_2}$$

T_2 is the decay constant of the signal in the xy plane or the transverse relaxation time constant.

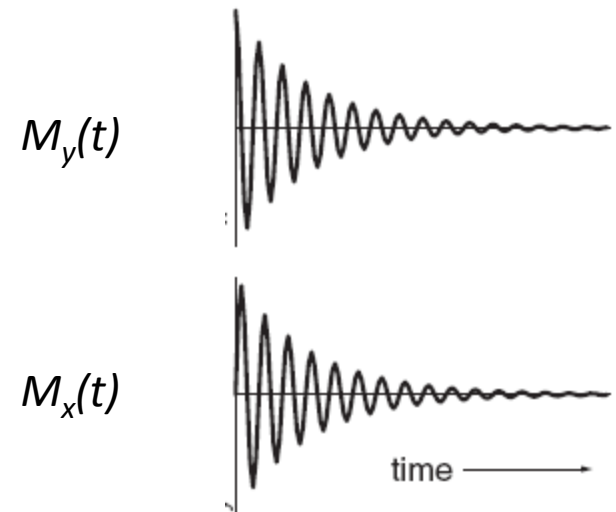
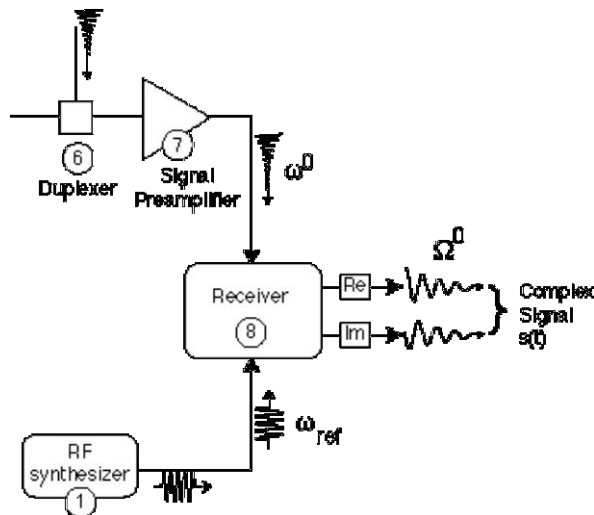

Sense of Rotation

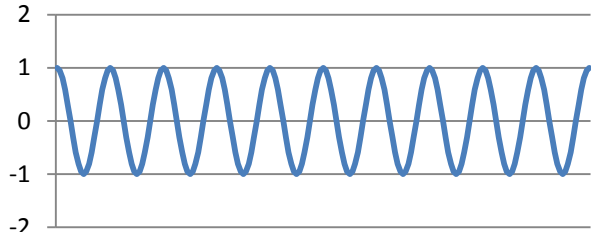

$$e^{i\Omega t} = \cos(\Omega t) + i \sin(\Omega t)$$

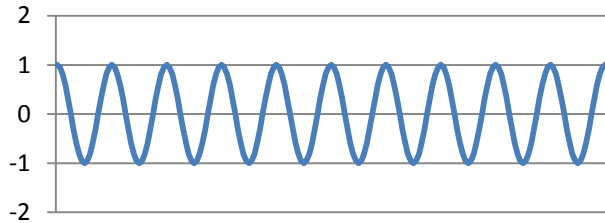
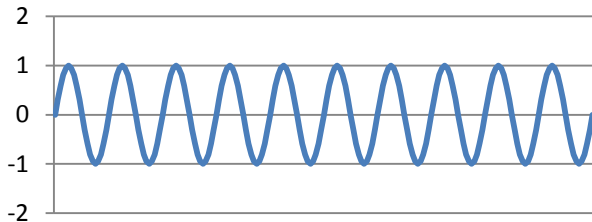
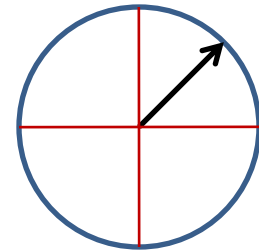

$$e^{-i\Omega t} = \cos(\Omega t) - i \sin(\Omega t)$$

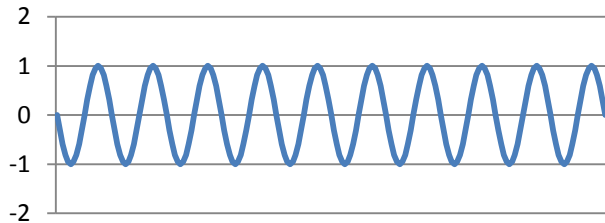
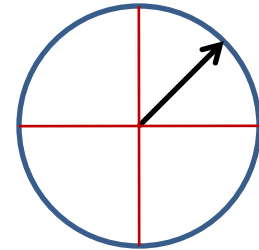

Quadrature Detected Signal

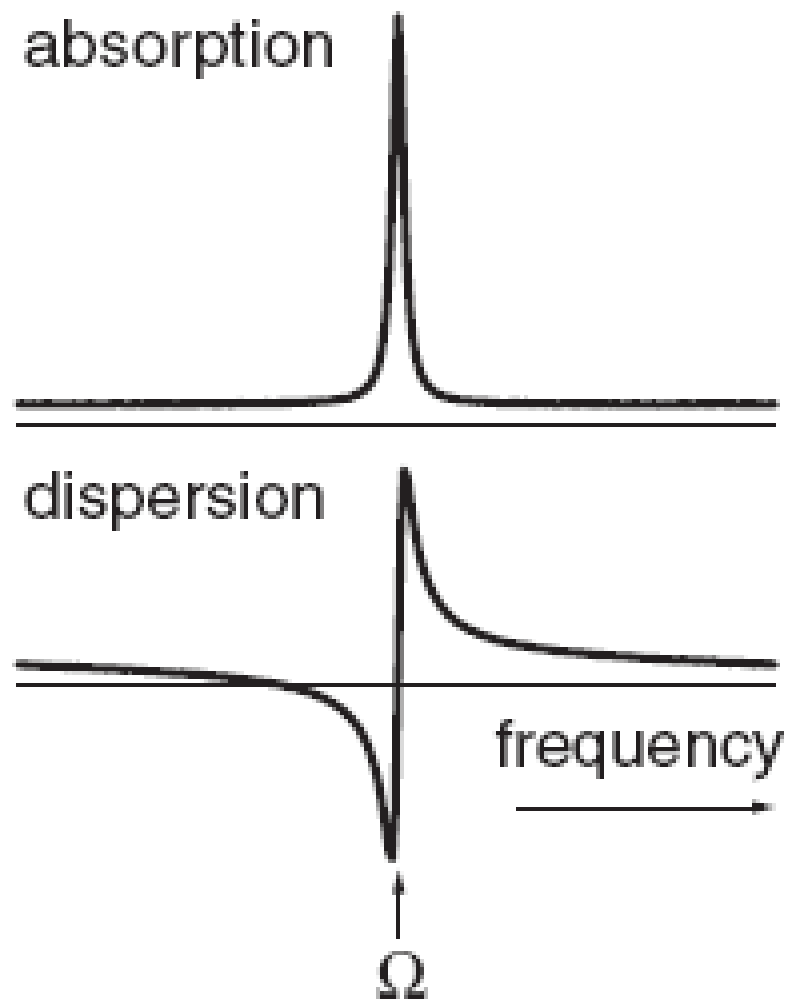

Amplitude Modulation

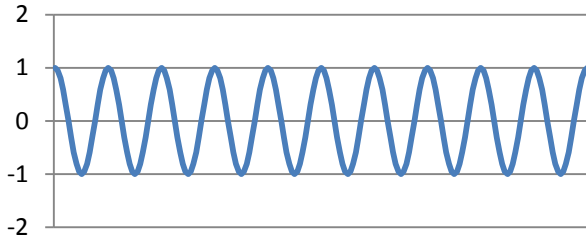

$$\cos(\Omega t) = \frac{1}{2}(e^{i\Omega t} + e^{-i\Omega t})$$

$$\frac{\lambda}{(\Omega - \omega)^2 + \lambda^2} + i \frac{(\Omega - \omega)}{(\Omega - \omega)^2 + \lambda^2}$$

$$\frac{\lambda}{(\Omega + \omega)^2 + \lambda^2} + i \frac{(\Omega + \omega)}{(\Omega + \omega)^2 + \lambda^2}$$

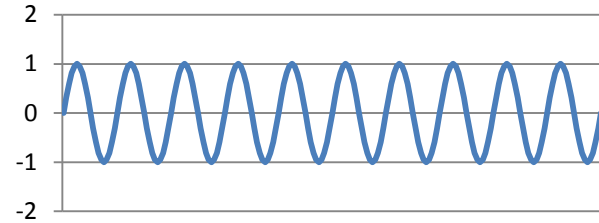
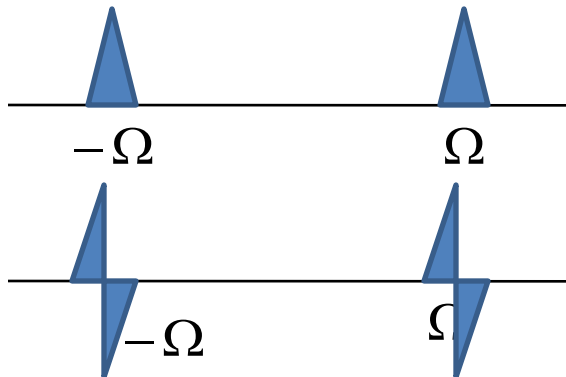

$$\sin(\Omega t) = \frac{1}{2i}(e^{i\Omega t} - e^{-i\Omega t})$$

$$\frac{\lambda}{(\Omega - \omega)^2 + \lambda^2} + i \frac{(\Omega - \omega)}{(\Omega - \omega)^2 + \lambda^2}$$

$$- \frac{\lambda}{(\Omega + \omega)^2 + \lambda^2} - i \frac{(\Omega + \omega)}{(\Omega + \omega)^2 + \lambda^2}$$

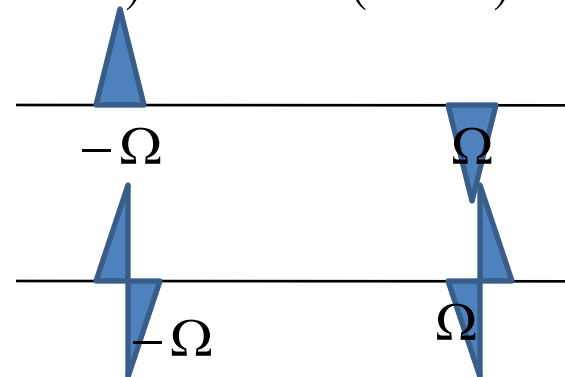

Quadrature Signal and Sampling

- For a faithful representation of a signal the sampling rate must be at least equal to twice the highest frequency (Nyquist theorem). For a spectral width of sw (in Hz) the sampling interval is

$$\Delta t = \frac{1}{2sw}$$

- In Quadrature detection, since positive and negative frequencies can be separated the center can be the reference frequency and then the sampling interval is

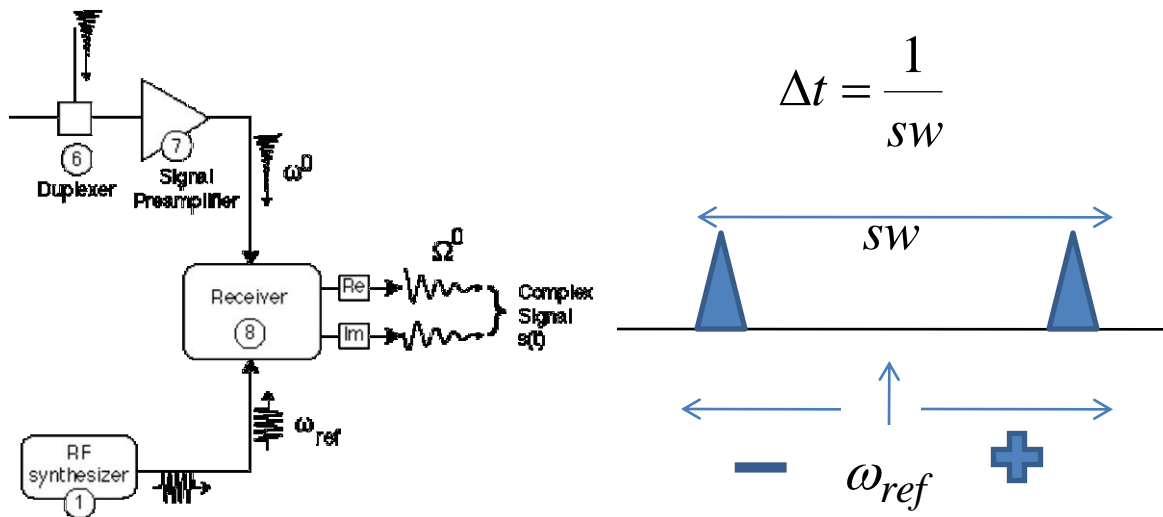

Quadrature Signal - TPPI

One method of generating quadrature signal just with one analog to digital converter (ADC) is by time proportional phase incrementation

$$\Delta t = \frac{1}{2sw}$$

$$s(t) = (s_x(0), s_y(\Delta t), -s_x(2\Delta t), -s_y(3\Delta t), \dots)$$

The resulting frequency shift is $\Delta\omega = \frac{\pi}{2\Delta t}$; $\Delta\nu = \frac{\Delta\omega}{2\pi} = \frac{sw}{2}$

The data points 1,3,5,... etc. are the cosine modulated part and the points 2,4,6,...etc. are the sine modulated part of the complex signal.

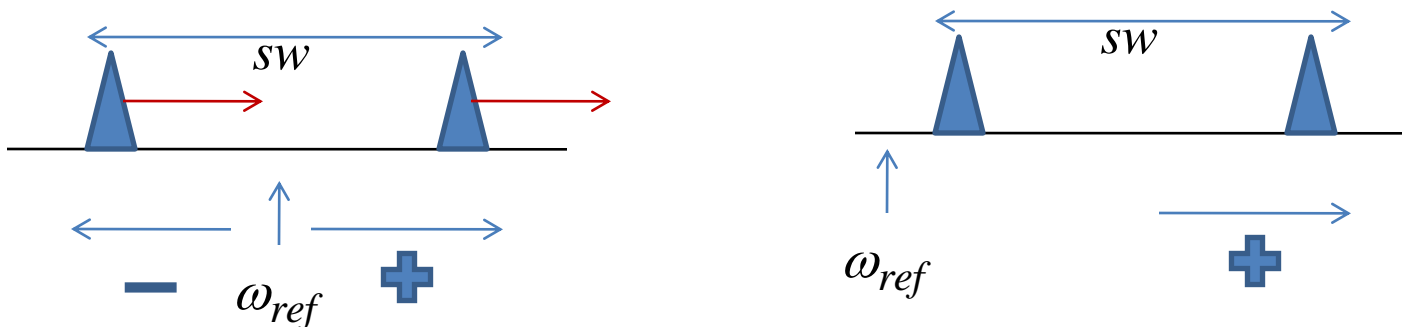

2D Signals

$$\begin{array}{l}
 I_z \\
 \downarrow 90_x \\
 -I_y \\
 \downarrow (\omega_I I_z) t_1
 \end{array}$$

$$-I_y \cos(\omega_I t_1) + I_x \sin(\omega_I t_1)$$

$$\downarrow (\pi J_{IS} 2I_z S_z) t_1$$

$$-I_y \cos(\omega_I t_1) \cos(\pi J_{IS} t_1) + 2I_x S_z \cos(\omega_I t_1) \sin(\pi J_{IS} t_1)$$

$$+ I_x \sin(\omega_I t_1) \cos(\pi J_{IS} t_1) + 2I_y S_z \sin(\omega_I t_1) \sin(\pi J_{IS} t_1)$$

$$\downarrow 90_x$$

Diagonal Peak

Cross Peak

$$-I_z \cos(\omega_I t_1) \cos(\pi J_{IS} t_1) - 2I_x S_y \cos(\omega_I t_1) \sin(\pi J_{IS} t_1)$$

$$+ I_x \sin(\omega_I t_1) \cos(\pi J_{IS} t_1) - 2I_z S_y \sin(\omega_I t_1) \sin(\pi J_{IS} t_1)$$

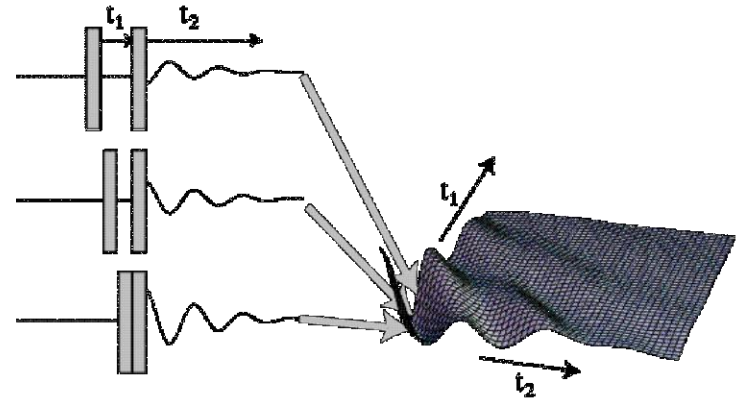

2D Signals

$$I_z$$

↓ 90_y

$$I_x$$

↓ $(\omega_I I_z) t_1$

$$I_x \cos(\omega_I t_1) + I_y \sin(\omega_I t_1)$$

↓ $(\pi J_{IS} 2I_z S_z) t_1$

$$I_x \cos(\omega_I t_1) \cos(\pi J_{IS} t_1) + 2I_y S_z \cos(\omega_I t_1) \sin(\pi J_{IS} t_1)$$

$$+ I_y \sin(\omega_I t_1) \cos(\pi J_{IS} t_1) - 2I_x S_z \sin(\omega_I t_1) \sin(\pi J_{IS} t_1)$$

90_x

Diagonal Peak

Cross Peak

$$I_x \cos(\omega_I t_1) \cos(\pi J_{IS} t_1) - 2I_z S_y \cos(\omega_I t_1) \sin(\pi J_{IS} t_1)$$

$$I_z \sin(\omega_I t_1) \cos(\pi J_{IS} t_1) + 2I_x S_y \sin(\omega_I t_1) \sin(\pi J_{IS} t_1)$$

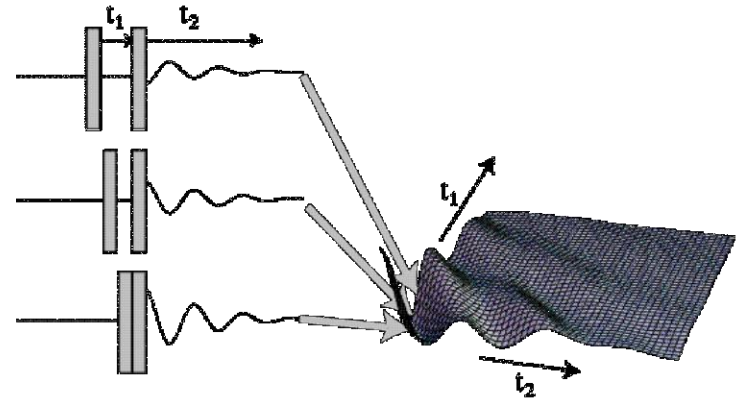

2D Signals

The time domain signal in a 2D experiment is:

$$s(t_1, t_2) = s_c(t_1, t_2) = \cos(\Omega_1 t_1) e^{-\lambda_1 t_1} \times e^{i\Omega_2 t_2 - \lambda_2 t_2}$$

$$s_c(t_1, t_2) = \frac{1}{2} (e^{i\Omega_1 t_1} + e^{-i\Omega_1 t_1}) e^{-\lambda_1 t_1} \times e^{i\Omega_2 t_2 - \lambda_2 t_2} = s_{P\text{-type}}(t_1, t_2) + s_{N\text{-type}}(t_1, t_2)$$

$$s(t_1, t_2) = s_s(t_1, t_2) = \sin(\Omega_1 t_1) e^{-\lambda_1 t_1} \times e^{i\Omega_2 t_2 - \lambda_2 t_2}$$

$$s_s(t_1, t_2) = -\frac{i}{2} (e^{i\Omega_1 t_1} - e^{-i\Omega_1 t_1}) e^{-\lambda_1 t_1} \times e^{i\Omega_2 t_2 - \lambda_2 t_2} = s_{P\text{-type}}(t_1, t_2) - s_{N\text{-type}}(t_1, t_2)$$

$$s(\omega_1, \omega_2) = \int_0^{\infty} dt_1 e^{-i\omega_1 t_1} \int_0^{\infty} dt_2 e^{-i\omega_2 t_2} s(t_1, t_2)$$

2D - Spectrum

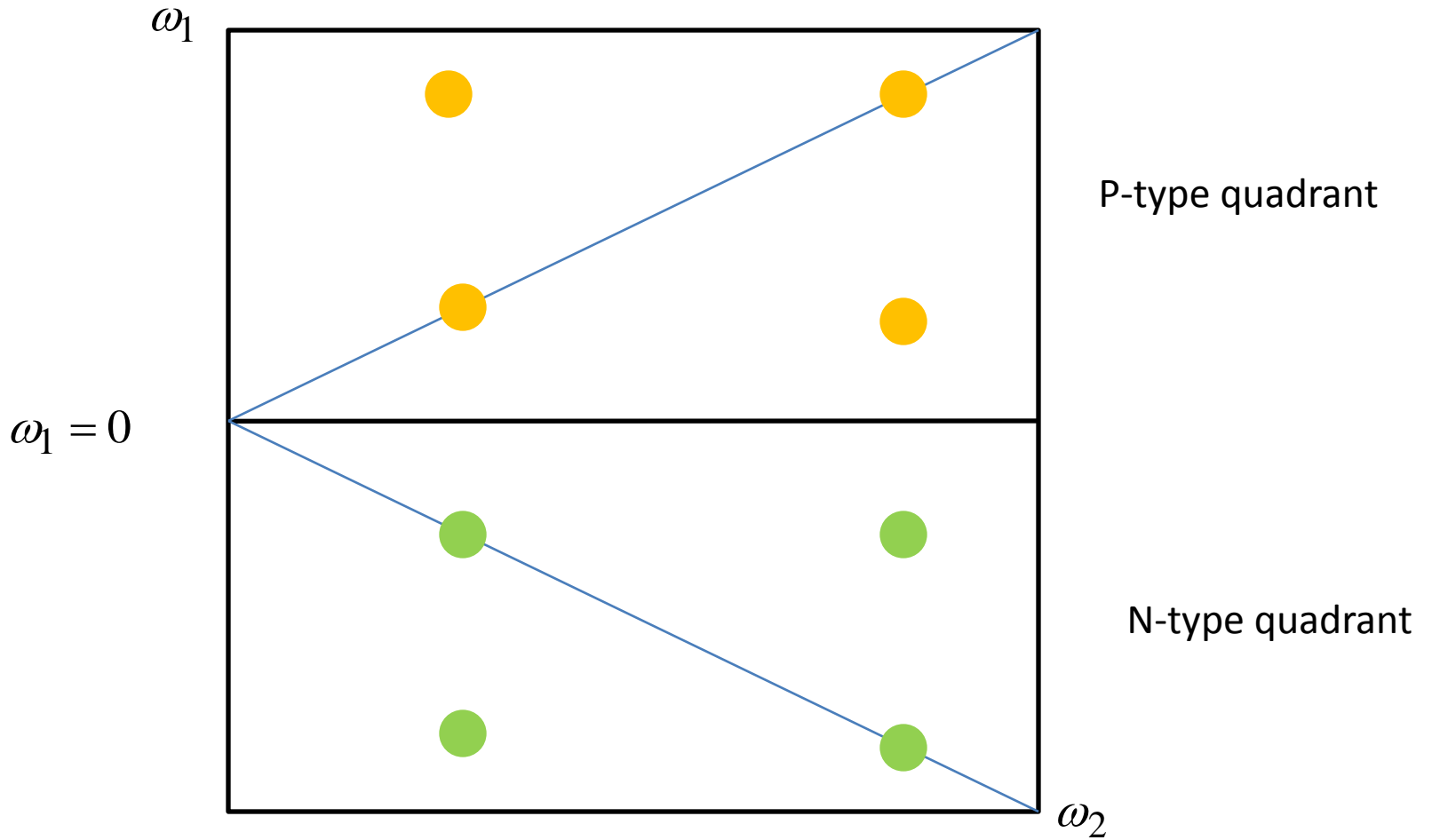

2D Lineshapes

Double Absorption

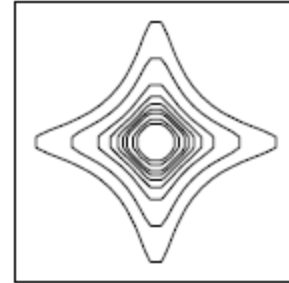
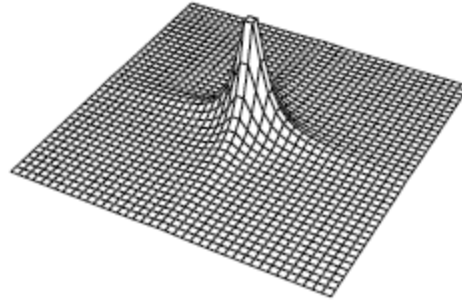

Desired
Lineshape

Double Dispersion

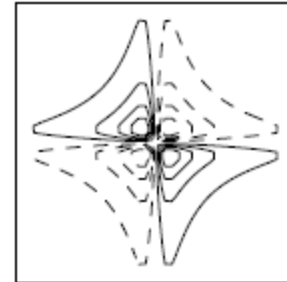
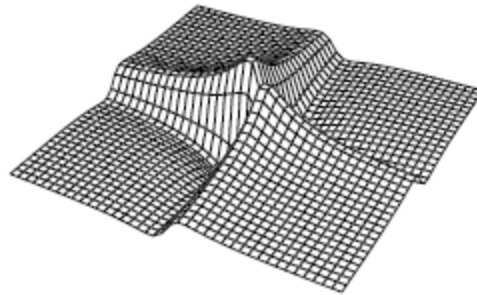

2D FT

The Frequency domain signal in a 2D experiment is:

$$s(\omega_1, \omega_2) = \int_0^{\infty} dt_1 e^{-i\omega_1 t_1} \int_0^{\infty} dt_2 e^{-i\omega_2 t_2} s(t_1, t_2)$$

In general the time domain and frequency domain signals can be expressed as complex signals.

$$s(t_1, t_2) = \text{Re}\{s(t_1, t_2)\} + i \text{Im}\{s(t_1, t_2)\} = s_r(t_1, t_2) + i s_i(t_1, t_2)$$

$$s(\omega_1, \omega_2) = \text{Re}\{s(\omega_1, \omega_2)\} + i \text{Im}\{s(\omega_1, \omega_2)\} = s_r(\omega_1, \omega_2) + i s_i(\omega_1, \omega_2)$$

The complex FT itself can be expressed as cosine and sine transforms, since

$$e^{i\omega_1 t_1} = \cos(\omega_1 t_1) - i \sin(\omega_1 t_1); e^{i\omega_2 t_2} = \cos(\omega_2 t_2) - i \sin(\omega_2 t_2)$$

$$s(\omega_1, \omega_2) = (\mathfrak{F}_c^1 - i\mathfrak{F}_s^1)(\mathfrak{F}_c^2 - i\mathfrak{F}_s^2)\{s_r(t_1, t_2) + i s_i(t_1, t_2)\}$$

2D FT

$$s_r(\omega_1, \omega_2) = \mathfrak{F}^{cc}\{s_r\} - \mathfrak{F}^{ss}\{s_r\} + \mathfrak{F}^{cs}\{s_i\} + \mathfrak{F}^{sc}\{s_i\}$$

$$s_i(\omega_1, \omega_2) = -\mathfrak{F}^{cs}\{s_r\} - \mathfrak{F}^{sc}\{s_r\} + \mathfrak{F}^{cc}\{s_i\} - \mathfrak{F}^{ss}\{s_i\}$$

$$\mathfrak{F}^{cc}\{s_r\} = \int_0^{\infty} dt_1 \cos(\omega_1 t_1) \int_0^{\infty} dt_2 \cos(\omega_2 t_2) s_r(t_1, t_2)$$

$$\mathfrak{F}^{cs}\{s_r\} = \int_0^{\infty} dt_1 \cos(\omega_1 t_1) \int_0^{\infty} dt_2 \sin(\omega_2 t_2) s_r(t_1, t_2)$$

$$\mathfrak{F}^{sc}\{s_r\} = \int_0^{\infty} dt_1 \sin(\omega_1 t_1) \int_0^{\infty} dt_2 \cos(\omega_2 t_2) s_r(t_1, t_2)$$

$$\mathfrak{F}^{ss}\{s_r\} = \int_0^{\infty} dt_1 \sin(\omega_1 t_1) \int_0^{\infty} dt_2 \sin(\omega_2 t_2) s_r(t_1, t_2)$$

2D FT

$$s(t_1, t_2) = s_c(t_1, t_2) = \cos(\Omega_1 t_1) e^{-\lambda_1 t_1} \times e^{i\Omega_2 t_2 - \lambda_2 t_2}$$

$$s_c(t_1, t_2) = \frac{1}{2} (e^{i\Omega_1 t_1} + e^{-i\Omega_1 t_1}) e^{-\lambda_1 t_1} \times e^{i\Omega_2 t_2 - \lambda_2 t_2} = s_{P\text{-type}}(t_1, t_2) + s_{N\text{-type}}(t_1, t_2)$$

A complex FT along t_2 and a real cosine FT along t_1 or complex FT along t_2 and keeping only the real part and complex FT along t_1 will yield

$$s_c(\omega_1, \omega_2) = A_1(\omega_1)A_2(\omega_2) + A_{-1}(-\omega_1)A_2(\omega_2)$$

Similarly for the sine modulated signal

$$s_s(\omega_1, \omega_2) = -i[A_1(\omega_1)A_2(\omega_2) - A_{-1}(-\omega_1)A_2(\omega_2)]$$

2D - Spectrum

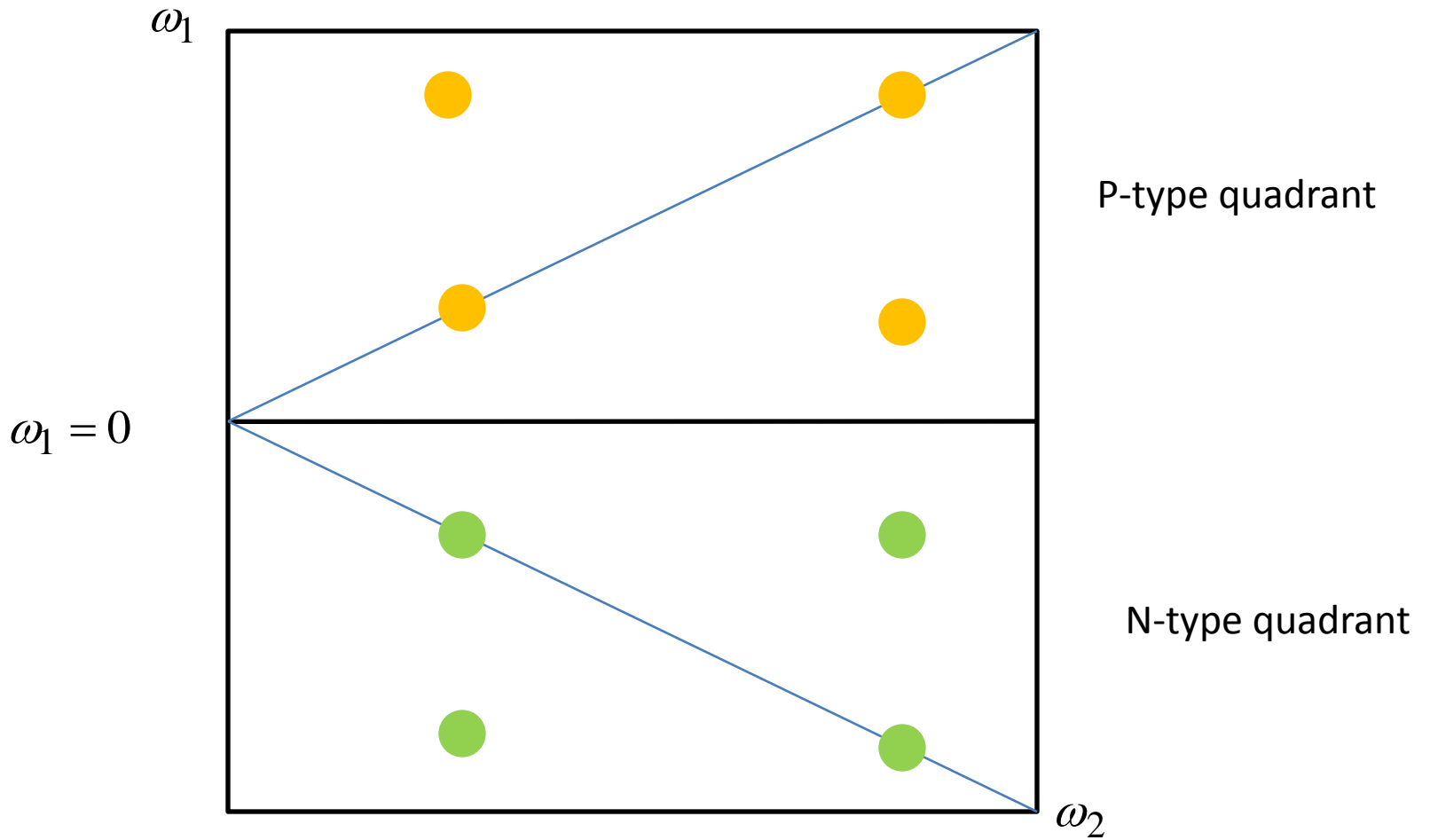

States Method of Quadrature

- Record two sets of data one yielding $s_c(t_1, t_2)$ and another $s_s(t_1, t_2)$ – a hypercomplex signal

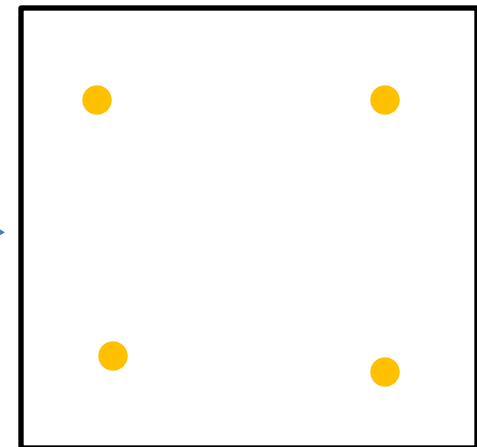
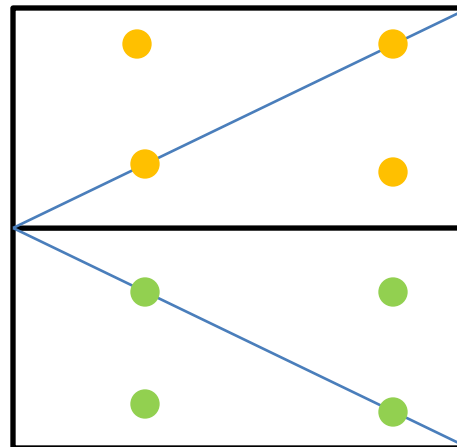
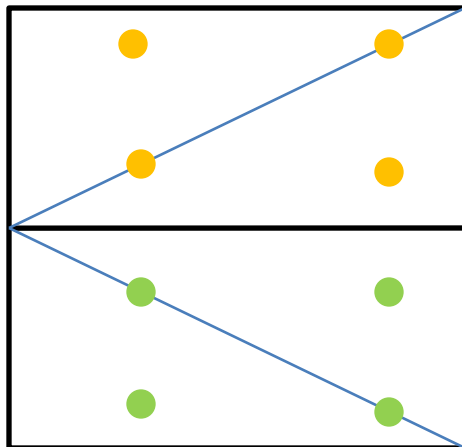
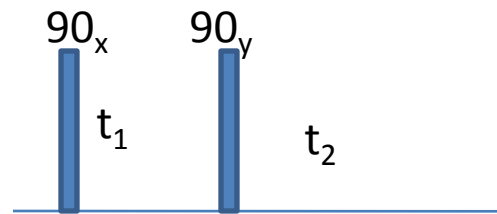
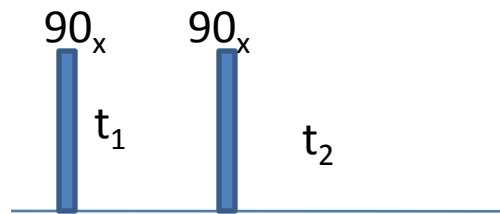

Hypercomplex FT-States Method

$$\cos(\Omega_1 t_1) e^{-\lambda_1 t_1} e^{(-i\Omega_2 - \lambda_2) t_2}$$

↓ FT - t_2

$$\cos(\Omega_1 t_1) e^{-\lambda_1 t_1} [A_2(\omega_2) - iD_2(\omega_2)]$$

$$\sin(\Omega_1 t_1) e^{-\lambda_1 t_1} e^{(-i\Omega_2 - \lambda_2) t_2}$$

↓ FT - t_2

$$\sin(\Omega_1 t_1) e^{-\lambda_1 t_1} [A_2(\omega_2) - iD_2(\omega_2)]$$

$$A_2(\omega_2) \cos(\Omega_1 t_1) e^{-\lambda_1 t_1} - iA_2(\omega_2) \sin(\Omega_1 t_1) e^{-\lambda_1 t_1}$$

$$A_2(\omega_2) [\cos(\Omega_1 t_1) - i \sin(\Omega_1 t_1)] e^{-\lambda_1 t_1}$$

$$A_2(\omega_2) e^{-i\Omega_1 t_1} e^{-\lambda_1 t_1}$$

↓ FT - t_1

$$A_2(\omega_2) [A_1(\omega_1) - iD_1(\omega_1)]$$

$$A_2(\omega_2) A_1(\omega_1)$$

Hypercomplex FT-States Method

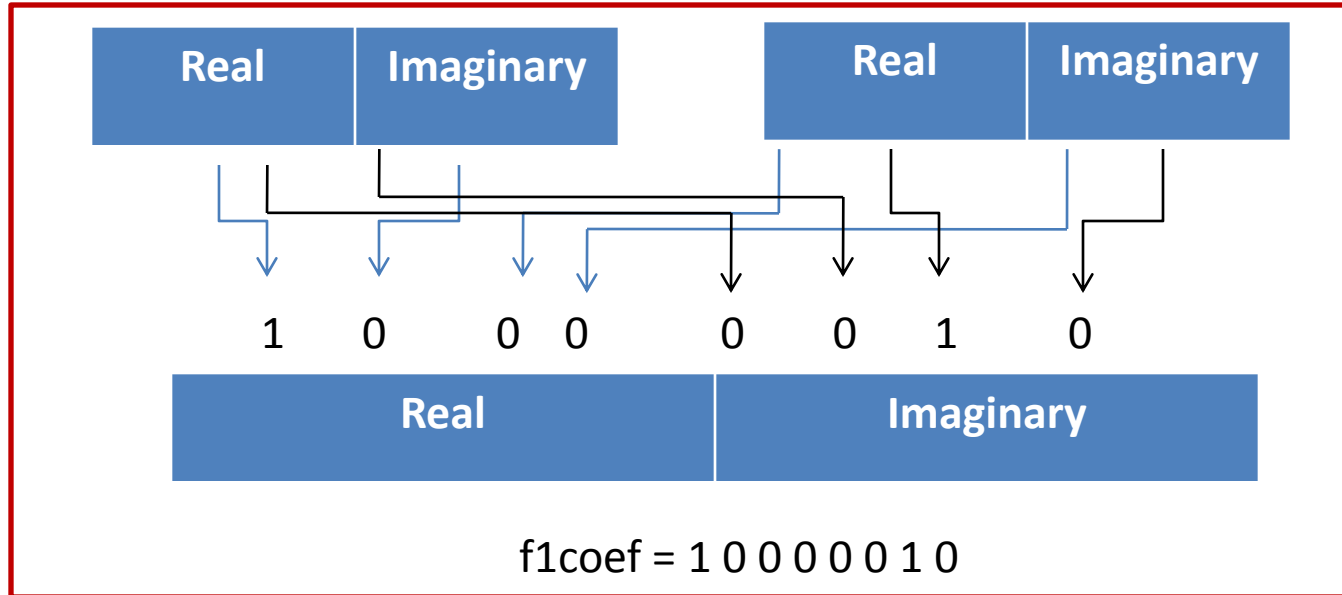

Phase
Cycled
Experiments

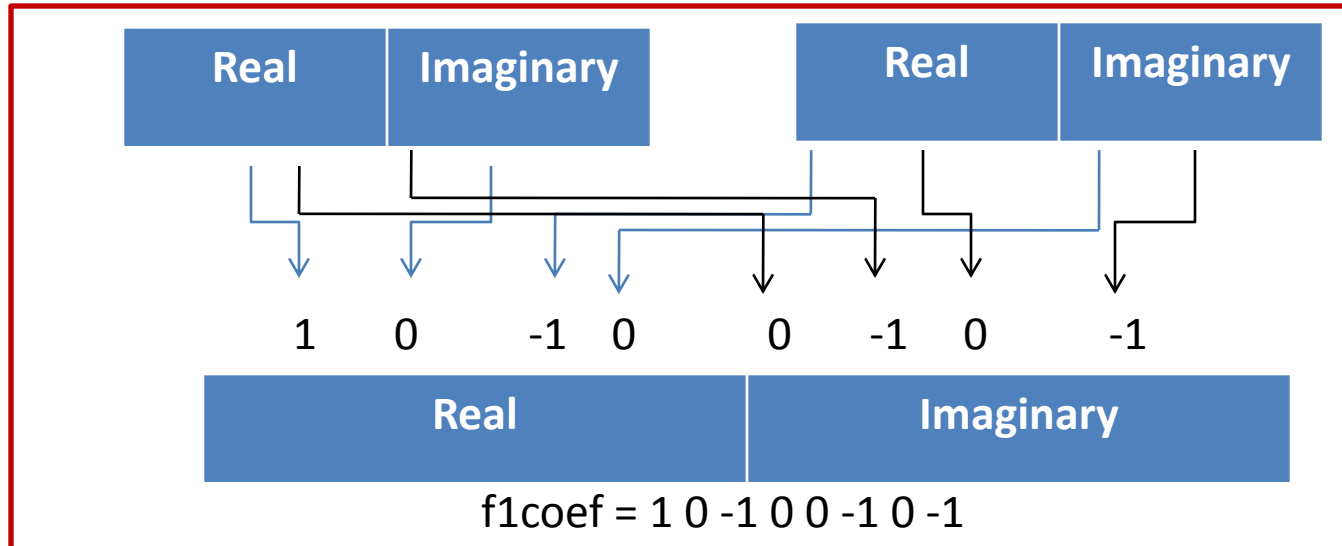

Gradient
Selected
Experiments

States Method

Cosine Modulated

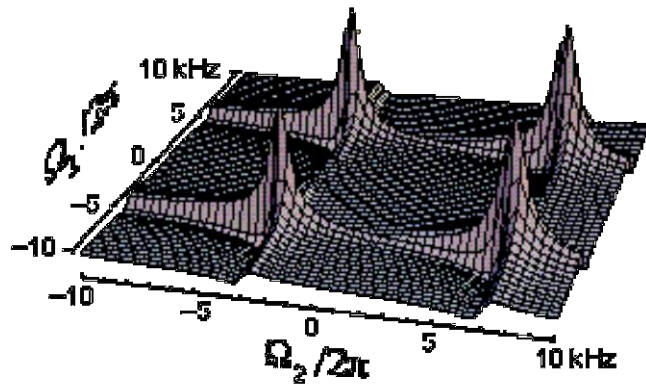

Sine Modulated

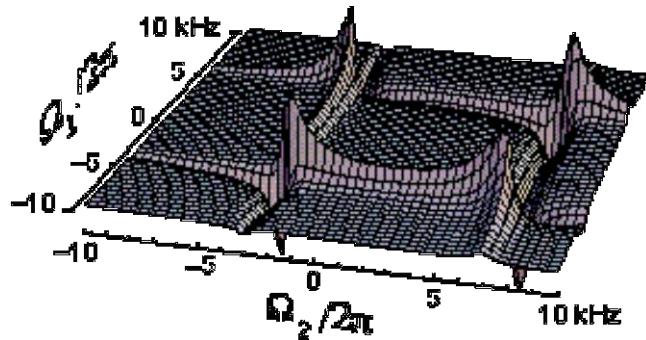

'States' spectrum

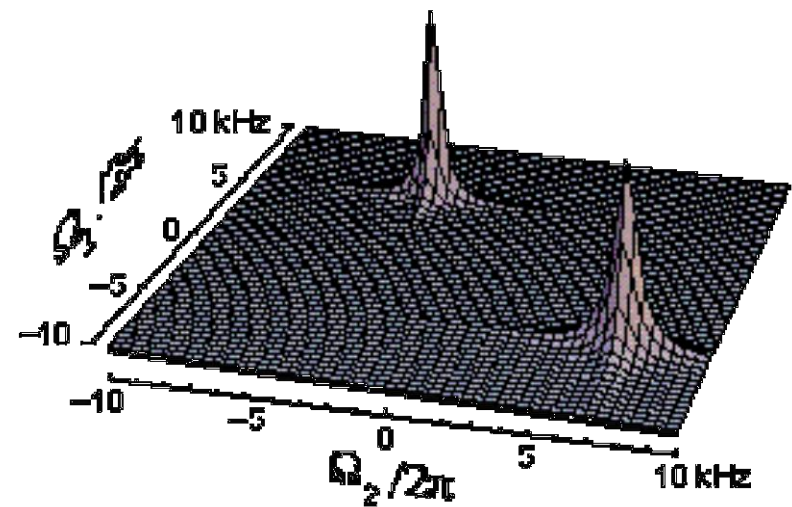

TPPI in t_1

Instead of collecting two different data sets as discussed before, TPPI method can be applied to the indirect dimension by incrementing the phase of the pulse by 90° in successive t_1 increments.

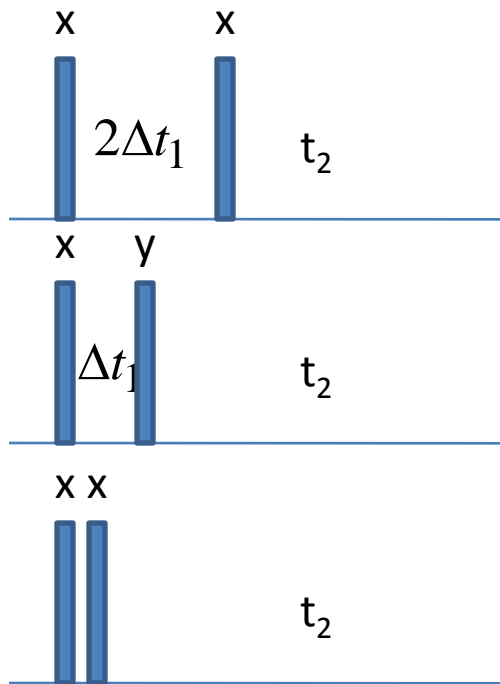

$$\Delta t_1 = \frac{1}{2sw_1}$$

For the same $t_{1\max}$ in both States and TPPI method the total acquisition time is the same.

The data points 1,3,5,... etc. are the sine modulated part and the points 2,4,6,...etc. are the cosine modulated part of the complex signal.

TPPI in t_1

$$s_{\text{odd}}(t_1) = \cos(\Omega_1 t_1) \cos(\pi s w_1 t_1) = \frac{1}{2} [\cos(\Omega_1 + \pi s w_1) t_1 + \cos(\Omega_1 - \pi s w_1) t_1]$$

$$s_{\text{even}}(t_1) = \sin(\Omega_1 t_1) \sin(\pi s w_1 t_1) = \frac{1}{2} [\cos(\Omega_1 - \pi s w_1) t_1 - \cos(\Omega_1 + \pi s w_1) t_1]$$

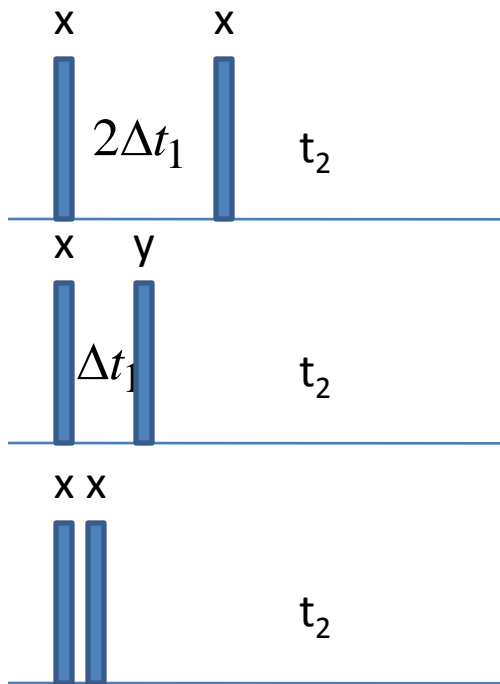

$$\Delta t_1 = \frac{1}{2s w_1}$$

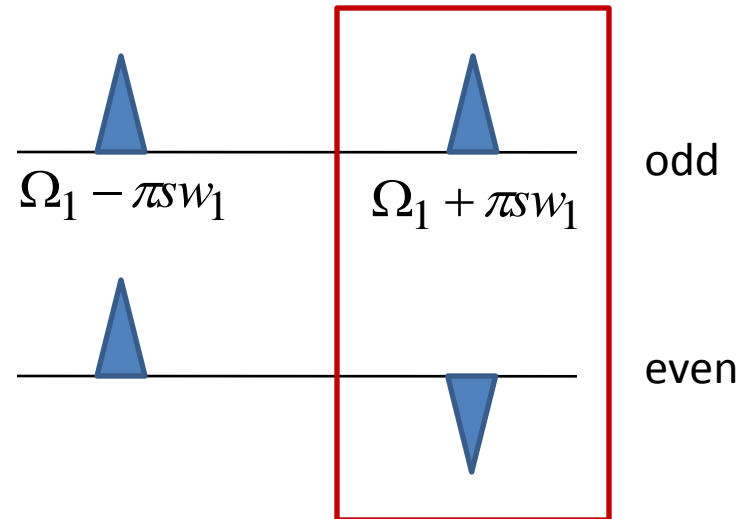

Quadrature Detection Methods

Experiment	Increment	Pulse Phase	Receiver Phase
TPPI			
1	$t_1(0)$	x	x
2	$t_1(0)+\Delta$	x	y
3	$t_1(0)+2\Delta$	-x	-x
4	$t_1(0)+3\Delta$	-y	-y
States			
1	$t_1(0)$	x	x
2	$t_1(0)$	y	x
3	$t_1(0)+2\Delta$	x	x
4	$t_1(0)+2\Delta$	y	y
TPPI-States			
1	$t_1(0)$	x	x
2	$t_1(0)$	y	x
3	$t_1(0)+2\Delta$	-x	-x
4	$t_1(0)+2\Delta$	-y	-y

$$\Delta = \frac{1}{2s\omega_1}$$

Folding

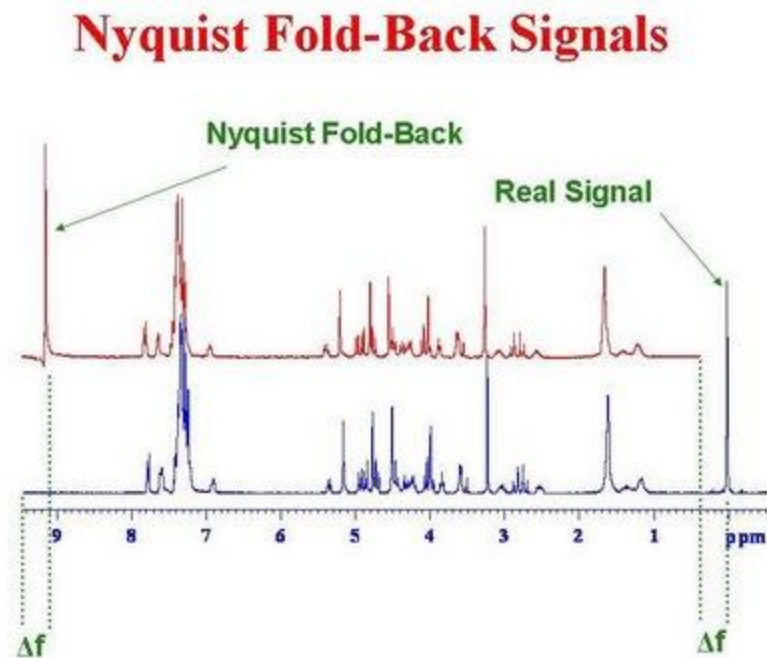
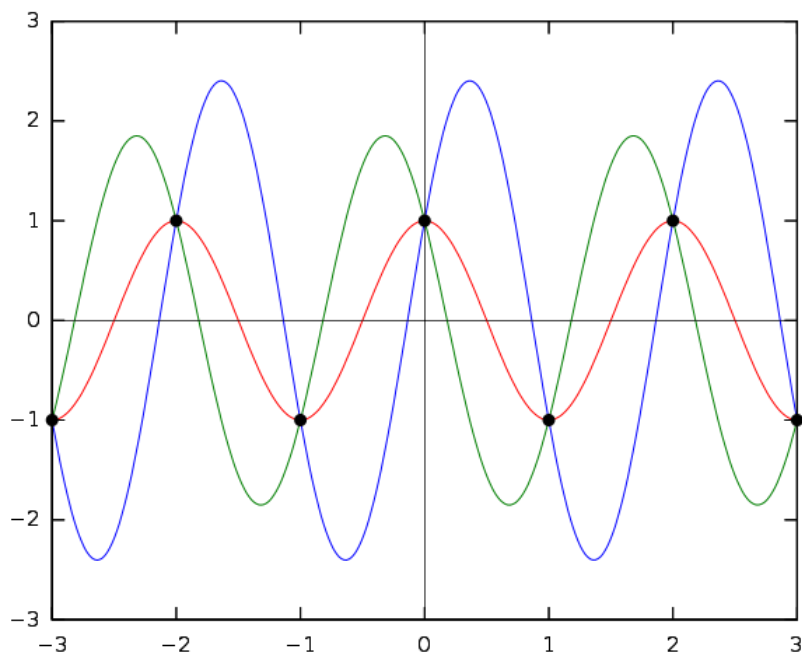

Folding in Indirect Dimension

States Method

Axial Peaks occur at $\omega_1=0$

TPPI Method

Axial Peaks occur at the edges of the spectrum since phase cycle does not affect the axial peaks.

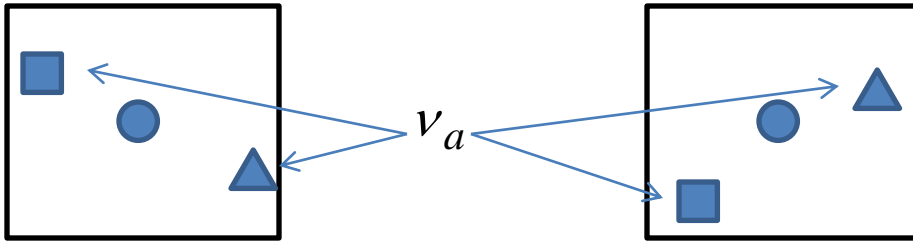
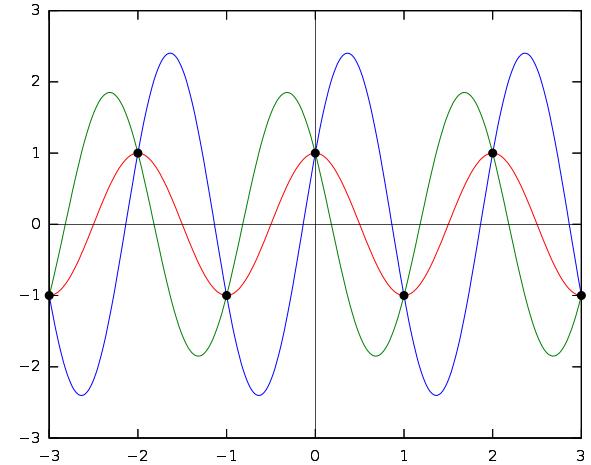

$$v > v_N; v_N = \frac{1}{2\Delta t}$$

$$v_a = v - 2m v_N$$

$$v > v_N; v_N = \frac{1}{2\Delta t}$$

$$v_a = (-1)^m (v - 2m v_N)$$

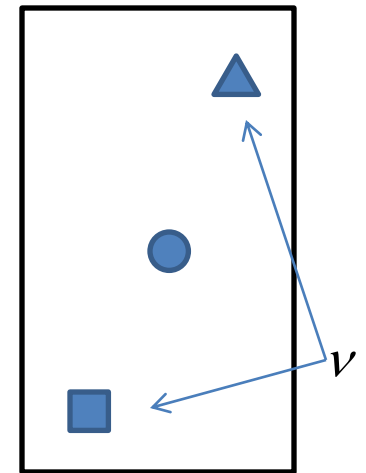

Folding in HSQC

